

Atlas Copco Rock Drilling Tools

SECOROC Integral equipment



Productivity is an integral part of our drill rods

Given that we've been mining and breaking rock for more than 600 years, you can safely assume that we know a lot about rock drilling. That knowledge is reflected in our product range – right down to the smallest detail. In the 1940s, we pioneered the development of integral systems and solutions. To meet the tough demands of our many customers in the dimensional stone and underground mining industries, we've continued to invest in the production of premium quality integral drill rods. After all, when it comes to narrow hole diameters in small-scale drift or tunnel areas or dimensional stone quarries there's no substitute for first-rate rock drilling tools.

A product of quality control

The lowest cost per metre drilled is our guiding principle at Atlas Copco Secoroc. To live up to this motto, we never compromise on quality. That's why we didn't settle for less than super tough C253 steel when we designed our integral drill rods.

Our manufacturing process matches the quality of the raw material. Inserts are subjected to a high quality bronze-brazing process – using just the right temperature and technique – to reduce the risk of carbide failure. And the shank is through-hardened to ensure the highest possible toughness and wear resistance.

What's more, our integral drill rods are unique in featuring a rolled-in stainless steel lining in the flushing tube for unrivalled anti-corrosion protection. Naturally, this entire process is certified in accordance with ISO 9001.



Whatever the application, we have the solutions to match

To meet diverse demands, we supply hexagonal rods, 19 mm and 22 mm in a wide variety of lengths and bit dimensions. But there's a lot more to our offer than the actual products. As a customer of Atlas Copco Secoroc, you enjoy access to application knowledge, training and technical support. And thanks to our global presence, we're never more than a phone call away.



An inside look at a state-of-the-art solution

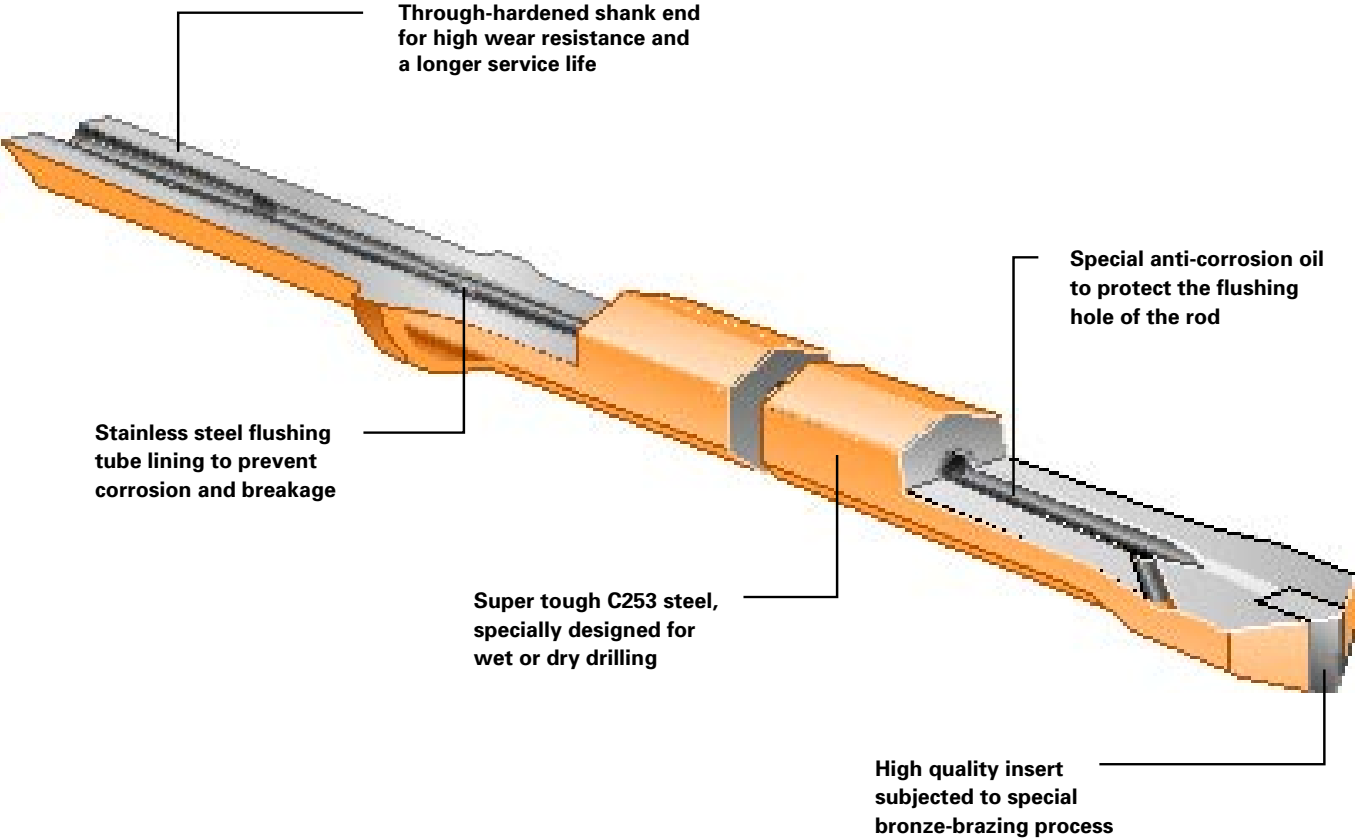

Integral drill rods

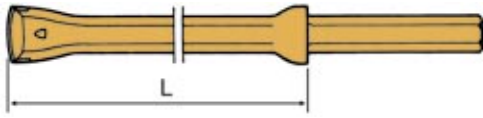

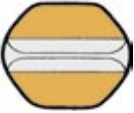

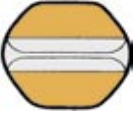
19 mm (3/4")	Series	Part No.	Length		Bit diameter		Weight approx. kg	
			mm	foot	mm	inch		
 <p>Chisel bit integral. Rod 19 mm (3/4"). Shank hex. 19 mm (3/4") x 108 mm (4 1/4").</p>	21	724-0429,06-02	400	1' 4"	29	1 9/64	1.3	
		724-0529,06-02	500	1' 8"	29	1 9/64	1.5	
		724-0828,06-02	800	2' 7"	28	1 7/64	2.2	
		724-1028,06-02	1000	3' 3 3/8"	28	1 7/64	2.6	
		724-1227,06-02	1200	3' 11"	27	1 1/16	3.0	
		724-1627,06-02	1600	5' 3"	27	1 1/16	3.9	
		724-2426,06-02	2400	7' 10"	26	1 1/32	5.7	
		724-3225,06-02	3200	10' 6"	25	1	7.5	
	724-4024,06-02	4000	13' 1"	24	15/16	9.2		
	22	724-0424,06-02	400	1' 4"	24	15/16	1.3	
		724-0823,06-02	800	2' 7"	23	29/32	2.2	
	24	724-0627,06-02	600	2'	27	1 1/16	1.7	
		724-1226,06-02	1200	3' 11"	26	1 1/32	3.0	
		724-2024,06-02	2000	6' 7"	24	15/16	4.8	
		724-2424,06-02	2400	7' 10"	24	15/16	5.7	
		724-2724,06-02	2700	8' 10"	24	15/16	6.3	
	25	724-0435,06-02	400	1' 4"	35	1 3/8	1.3	
		724-0834,06-02	800	2' 7"	34	1 11/32	2.2	
	<p>Chisel bit integral. Rod 19 mm (3/4"). Shank hex. 22 mm (7/8") x 108 mm (4 1/4"). Seal part no. 9159 (if needed).</p>		728-0424,06-02	400	1' 4"	24	15/16	1.5
			728-0429,06-02	400	1' 4"	29	1 9/64	1.5
		728-0627,06-02	600	2'	27	1 1/16	1.7	
		728-0823,06-02	800	2' 7"	23	29/32	2.3	
		728-0828,06-02	800	2' 7"	28	1 7/64	2.3	
		728-1223,06-02	1200	3' 11"	23	29/32	3.2	
		728-1627,06-02	1600	5' 3"	27	1 1/16	4.0	
		728-2028,06-02	2000	6' 7"	28	1 7/64	5.0	
		728-2426,06-02	2400	7' 10"	26	1 11/32	5.8	
		728-3225,06-02	3200	10' 6"	25	1	7.5	

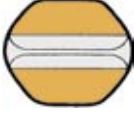
22 mm (7/8")	Series	Part No.	Length		Bit diameter		Weight approx. kg
			mm	foot	mm	inch	
 <p>Chisel bit integral. Rod 22 mm (7/8"). Shank hex. 22 mm (7/8") x 108 mm (4 1/4"). Seal part no. 9159 (if needed).</p>	11	714-0834,05-02	800	2' 7"	34	1 11/32	3.0
		714-1633,05-02	1600	5' 3"	33	1 5/16	5.2
		714-2432,05-02	2400	7' 10"	32	1 1/4	8.0
		714-3231,05-02	3200	10' 6"	31	1 7/32	10.2
		714-4030,05-02	4000	13' 1"	30	1 3/16	12.9
		714-4829,05-02	4800	15' 9"	29	1 9/64	15.1
		714-5628,05-02	5600	18' 4"	28	1 7/64	17.6
		714-6427,05-02	6400	21'	27	1 1/16	20.1
		714-7226,05-02	7200	23' 6"	26	1 1/32	22.5
		12	714-0840,05-02	800	2' 7"	40	1 37/64
	714-1639,05-02		1600	5' 3"	39	1 17/32	5.2
	714-2438,05-02		2400	7' 10"	38	1 1/2	8.0
	714-3237,05-02		3200	10' 6"	37	1 29/64	10.2
	714-4036,05-02		4000	13' 1"	36	1 7/16	12.9
	714-4835,05-02		4800	15' 9"	35	1 3/8	15.1
	714-5634,05-02		5600	18' 4"	34	1 11/32	17.6
	714-6433,05-02		6400	21'	33	1 5/16	20.1
	714-7232,05-02		7200	23' 7"	32	1 1/4	22.5
	714-8031,05-02		8000	26' 2"	31	1 7/32	25.0

22 mm (7/8"), cont		Series	Part No.	Length		Bit diameter		Weight approx. kg
				mm	foot	mm	inch	
 <p>Chisel bit integral. Rod 22 mm (7/8"). Shank hex. 22 mm (7/8") x 108 mm (4 1/4"). Seal part no. 9159 (if needed).</p>	13	714-0434,05-02	400	1' 4"	34	1 11/32	1.7	
		714-0833,05-02	800	2' 7"	33	1 5/16	3.0	
		714-1232,05-02	1200	3' 11"	32	1 1/4	4.1	
		714-1631,05-02	1600	5' 3"	31	1 7/32	5.2	
		714-2030,06-02	2000	6' 7"	30	1 3/16	6.7	
		714-0635,05-02	600	2'	35	1 3/8	2.7	
	16	714-1234,05-02	1200	3' 11"	34	1 11/32	4.1	
		714-1833,05-02	1800	5' 11"	33	1 5/16	6.0	
		714-2432,05-02	2400	7' 10"	32	1 1/4	8.0	
		17	714-0641,05-02	600	2'	41	1 5/8	2.4
	714-1240,05-02		1200	3' 11"	40	1 37/64	4.3	
	714-1839,05-02		1800	5' 11"	39	1 17/32	6.2	
	714-2438,05-02		2400	7' 10"	38	1 1/2	8.0	
		714-0441,05-02	400	1' 4"	41	1 5/8	1.7	
		714-0435,05-02	400	1' 4"	35	1 3/8	1.7	
		714-0829,05-02	800	2' 7"	29	1 9/64	3.0	
		714-0838,05-02	800	2' 7"	38	1 1/2	3.1	
		714-1233,05-02	1200	3' 11"	33	1 5/16	4.1	
		714-1239,05-02	1200	3' 11"	39	1 17/32	4.3	
		714-1628,05-02	1600	5' 3"	28	1 7/64	5.2	
		714-1636,05-02	1600	5' 3"	36	1 27/64	5.2	
		714-1836,05-02	1800	5' 11"	36	1 27/64	6.0	
		714-2032,05-02	2000	6' 7"	32	1 1/4	6.7	
		714-2033,05-02	2000	6' 7"	33	1 5/6	6.7	
		714-2133,05-02	2100	6' 11"	33	1 5/6	7.0	
		714-2427,05-02	2400	7' 10"	27	1 1/16	8.0	
		714-3227,05-02	3200	10' 6"	27	1 1/16	10.2	
		714-3228,05-02	3200	10' 6"	28	1 7/64	10.3	
		714-3232,05-02	3200	10' 6"	32	1 1/4	10.3	
		714-6430,05-02	6400	21'	30	1 3/16	20.1	
		714-8026,05-02	8000	26' 2"	26	1 1/32	25.0	
		714-9629,05-02	9600	31' 6"	29	1 9/64	30.0	

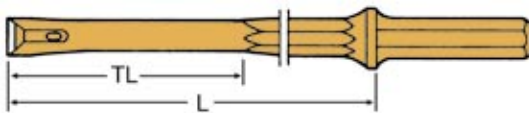
Plug hole rods



19 mm (3/4")		Part No.	Length		Bit diameter		Turned length (TL)		Weight approx. kg
			mm	foot/inch	mm	inch	mm	inch	
 <p>Chisel bit plug hole rod. Shank hex 19 mm (3/4") x 108 mm (4 1/4").</p>	721-2117-15,05-02	210	8 1/4"	17	43/64	150	5 7/8	0.7	
	721-2120-15,05-02	210	8 1/4"	20	25/32	150	5 7/8	0.7	
	721-2122-15,05-02	210	8 1/4"	22	7/8	150	5 7/8	0.7	
	721-2620-20,05-02	260	10 1/4"	20	25/32	200	7 7/8	0.8	
	721-2622-20,05-02	260	10 1/4"	22	7/8	200	7 7/8	0.8	
	721-3122-25,05-02	310	1' 1/4"	22	7/8	250	10	0.9	
	721-3420-28,05-02	340	1' 11/2"	20	25/32	280	11	1.0	
Shank hex 19 mm (3/4") x 82 mm (3 1/4") shank	722-2120-15,05-02	210	8 1/4"	20	25/32	150	5 7/8	0.7	
	722-2122-15,05-02	210	8 1/4"	22	7/8	150	5 7/8	0.7	

Secoroc grinding equipment for sharp-minded drillers

To meet the needs of sharp-minded drillers the world over, we offer Grind Matic, a comprehensive range of efficient, ergonomically designed grinding machines for fixed installations and field operations. Check out our range. Chances are you'll find just the right machine for your site.

Swing and Senior will soon have you back on the cutting edge

The Secoroc Grind Matic grinders, Swing and Senior, are two machines ideally suited to sharpening integral equipment. The latter is a sturdy and dependable grinder – specially designed for larger volumes. Grind Matic Senior features an adjustable cutting edge radius and angle. Grinding wheels are available for both wet and dry grinding.

If your site handles smaller volumes, we recommend Grind Matic Swing, a user-friendly, hassle-free grinding machine. Simply bolt it on to your rig or on to a workbench, and you'll be up and running in no time. You can also place it on some worn out integral rods, creating a tripod. Grind Matic Swing has a fixed setting for grinding, providing a cutting-edge angle of 110° and a cutting radius of 80 mm. Grinding wheels are available for both wet and dry grinding.



Grinding wheels for Swing and Senior – available for wet and dry grinding



Grind Matic Senior – for large-scale operations



Grind Matic Swing
– for smaller operations



Use a Secoroc grinding template to check when it's time for a regrind. The template will also help you make sure you've done the job properly.



Atlas Copco Secoroc AB
Phone: +46 223 461 00 Fax: +46 223 461 01
www.atlascopco.com